

LA-5791

03

UC-4

Reporting Date: October 1974

Issued: December 1974

**CIC-14 REPORT COLLECTION
REPRODUCTION
COPY**

Flameless Atomic Absorption Apparatus for Analyzing Alpha-Radioactive Materials

by

Lawrence E. Cox

LOS ALAMOS NATIONAL LABORATORY



3 9338 00368 3504

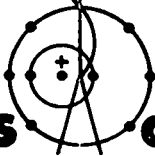

**los alamos
scientific laboratory**

of the University of California

LOS ALAMOS, NEW MEXICO 87544



UNITED STATES
ATOMIC ENERGY COMMISSION
CONTRACT W-7408-ENG. 36

An Equal Opportunity Employer

Printed in the United States of America. Available from
National Technical Information Service
U.S. Department of Commerce
5285 Port Royal Road
Springfield, VA 22151
Price: Printed Copy \$4.00 Microfiche \$2.25

This report was prepared as an account of work sponsored by the United States Government. Neither the United States nor the United States Atomic Energy Commission, nor any of their employees, nor any of their contractors, subcontractors, or their employees, make any warranty, express or implied, or assumes any legal liability or responsibility for the accuracy, completeness or usefulness of any information, apparatus, product or process disclosed, or represents that its use would not infringe privately owned rights.

FLAMELESS ATOMIC ABSORPTION APPARATUS FOR
ANALYZING ALPHA-RADIOACTIVE MATERIALS

by

Lawrence E. Cox

ABSTRACT

A flameless atomic absorption instrument was developed that analyzes trace impurities in uranium and plutonium with greater precision and accuracy than are obtained by carrier distillation emission spectroscopy methods. The apparatus includes a sequencer that provides drying, charring, and atomizing periods of preselected duration, and an analog integrator that automatically corrects baseline drift. The electronic components are placed outside a glovebox to prevent exposure to radioactivity. Typical relative standard deviations for aluminum, chromium, copper, iron, and nickel are 3 to 6%. Average biases for recovering elements from plutonium solutions range from 5 to 9%.



INTRODUCTION

For more than 25 yr, most trace constituent analyses in uranium and plutonium were obtained using the carrier distillation emission spectroscopy technique.¹ With this method, samples are ignited, mixed with a suitable carrier, and subjected to dc arc analysis in a crater-type electrode. Standards are prepared from the high-purity actinide oxide and from oxides of the desired impurity elements. Oxides are used so that the sample and standard matrices resemble each other as closely as possible. Twenty to thirty elements are determined by one exposure, and detection limits from 0.1 $\mu\text{g/g}$ for beryllium, boron, and lithium to 50 $\mu\text{g/g}$ for phosphorus are routinely attained. No other single technique presently offers greater speed and sensitivity of analysis for a wide range of elements.

The carrier distillation emission spectroscopy method, however, is affected by matrix composition; samples with widely differing impurity levels behave differently in the arc. Even when using an internal standard, we cannot always correct these differences. Also, its precision is limited to $\sim 20\%$ relative standard deviation (RSD) by the irrepro-

ducibility of the arcing process and by the variability of photographic detection.

With the advent of atomic absorption (AA) spectrophotometry in 1955, and later of the carbon furnace atomizer, trace metals were determined singly with much greater precision, accuracy, and sensitivity than was previously possible. Analysis of samples as solutions greatly reduces matrix effects, and the quantitative separability of uranium and plutonium from most other elements eliminates matrix problems. We implemented the AA apparatus with the expectation that its results would reveal possible biases in the other methods.

GENERAL CONSIDERATIONS

Plutonium-containing materials are handled in special gloved enclosures²⁻⁴ to ensure personnel safety. The glovebox is made of stainless steel, with safety glass viewing windows, and with fused silica light beam windows at both ends of the optical path. Hollow cathode radiation enters at one end, passes through a silica lens, the carbon furnace, and a second lens, then exits through the second window into the monochromator. The furnace

holder and the two lenses are the only components within the box, thus reducing radioactivity effects on the instrumentation.

Highly combustible gas mixtures usually used for AA are inadvisable without elaborate and expensive safety interlocks. Therefore, an electrically heated graphite furnace atomizer was used.

INSTRUMENTATION

Spectrometer. We chose the AA spectrometer (Jarrell Ash 82-500) because the hollow cathode turret and monochromator are separate units, allowing the source and detector to be placed outside the glovebox. Hollow cathode emission is electronically modulated at line frequency and ac detection is provided. This system does not seem to be significantly affected by furnace emission. However, to limit the monochromator's field of view, an iris diaphragm was placed ~ 102 mm from the furnace. Also included is a logarithmic amplifier that can be calibrated to read out in concentration units. The log output rather than the per cent absorption has proved most useful for our purposes.

Sequencer. Furnace AA involves placing a small drop (typically 1 to 10 μl) of sample into the furnace, applying a small current for 15 to 20 s to evaporate the solvent, increasing the current to char or decompose the matrix, and then atomizing the sample at a still higher current. To accomplish the sequencing, we developed the circuit shown in Fig. 1. The heart of the system consists of variacs V1, V2, and V3 and timers T1, T2, and T3. The cycle is initiated by starting dry timer T1, causing relay R11 to be energized, and putting V1 in the circuit with the transformer primary. At the same time, capacitor C1 is charged by the diode bridge D1-D4. At the end of the drying cycle, R11 is deenergized causing capacitor C1 to discharge through relay R14, energizing it momentarily. R14 is connected across the start switch of T2, causing its cycle to begin. The second variac is now in the circuit and capacitor C2 is being charged. When the charring cycle ends, the same sequence is repeated with C2, R15, and T3. The atomizing time and voltage are controlled by T3 and V3, respectively. Typical drying, charring, and atomizing times are 20, 10, and 3.5 s, respectively. Corresponding furnace temperatures and voltages are

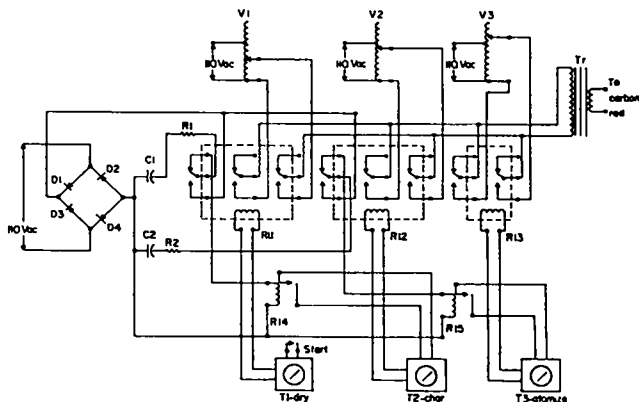

Fig. 1. Graphite furnace temperature sequencer. Components: D1-D4: IN4005; C1 and 2: 15 μF , 250 V; R1 and 2: 3.3 k Ω , 2W; R11 and 12: 3PDT, 15 A; R13: 2PDT, 15A; R14 and 15: SPST, 3 A; V1 and 2: 115-Vac primary, 0- to 135-Vac secondary, 8 A; V3: 115-Vac primary, 0- to 135-Vac secondary, 20 A; T1 and 2: Industrial Timer Corp. No. P-5M; T3: Industrial Timer Corp. No. P-4R; Tr: 115-Vac primary, 5.3-Vac secondary, 30 A, 6 transformers in parallel, 2 banks of 6 in series.

100 (20 V), 350 (35 V), and 2200 $^{\circ}\text{C}$ (110 V). Optimum conditions depend somewhat on the element of interest and matrix composition.

Signal Integration. Although peak absorbance is the parameter most widely used in flameless AA and there is ample evidence that integrated absorbance gives better precision and decreases the curvature of the calibration curve,^{5,6} we experienced difficulty with analog integration because of baseline drift caused largely by hollow cathode intensity changes. The most widely used solution to this problem is to split the beam into spatially separated sample and reference portions. Because the ratio of sample (I) to reference (I_0) intensity is unaffected by changes in source intensity, a log ratio amplifier provides a relatively drift-free readout of absorbance ($A = \log I_0/I$). If, however, the measurement time is short relative to the drift rate, the reference and sample intensity measurements can be temporally rather than spatially separated. That is, one assumes that during the few seconds required for measuring the transient absorption signal, hollow cathode and electronic drift are negligible. Implementation of such a system requires a means for holding $\log I_0$, measured

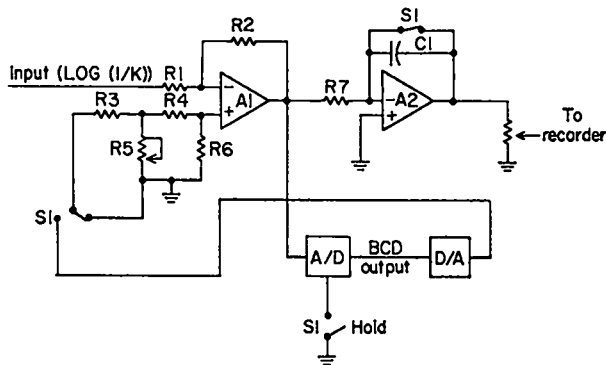

Fig. 2. Drift-compensating integrator. Components: A1 and 2: Intech A-148B; A/D converter: Data Technology 4312-01; D/A converter: Datel 4912-D; R1 and 4: 1 k Ω , 1%; R2, 3, and 6: 10 k Ω , 1%; R5: 20 Ω ; R7: 33 k Ω ; C1: 8 μ F, 50 V.

just before sample atomization, and subtracting log I from it, so that a voltage proportional to absorbance results during the atomizing cycle.

A circuit meeting this requirement is shown in Fig. 2. The output of the instrument's log amplifier is connected to the inverting input of the differential amplifier A1. The noninverting input is normally grounded. The input to A1 is amplified 10 times, converted to BCD form, held by the A/D converter, and returned to analog by the D/A converter. The initial amplification is required to establish compatibility between the 10-mV instrument output and the 200-mV A/D converter. Without it a digit would be lost in the BCD output, resulting in a loss of accuracy in the final analog voltage. Resistors R3 and R5 form a divider network effecting the necessary thousandfold reduction of the 10-V output of the D/A converter.

To initiate integration, S1 across the integrating capacitor is opened, the BCD output of the A/D converter is switched to hold, and the noninverting input of A1 is switched from ground to the output of the D/A converter. In our circuit, all three switching operations are effected simultaneously by a 4PDT relay. The success of this approach depends on the fact that the A/D is of the dual-slope integrating type and requires 250 ms for a conversion cycle. Although the input to the A/D converter begins to change when the positive input to A1 is switched, the BCD register contents do not change after the hold signal is applied.

The integrating register R7 and capacitor C1 are chosen to provide an appropriate time constant. Here we use R7 = 33 K and C1 = 8 μ F. The overall response time is now limited by the instrument's relatively slow AC amplifier.

The system's ability to compensate for substantial changes in baseline voltage is shown in Fig. 3. The recorder tracings of results for duplicate injections (5 μ l) of 0.2 μ g/ml chromium at three baseline values show that reproducibility is good and that the integrated absorbance values are independent of drift. For nonrefractory elements, we obtained typical RSDs of 1.5 to 3%. By displaying the instrument's log output during the drying and charring periods and the integrator output during the atomizing cycle, we can easily follow the solvent evaporation and absorption rates during the charring cycle. The integrator output is displayed for 5 to 10 s during and after the atomizing cycle, and it is easily distinguished from the other features by its duration.

Furnace Holder Assembly. We used a cylindrical furnace that provides greater sensitivity and less chance of recombination interference than a simple carbon rod, although its usable dynamic range is somewhat less.

The holder assembly (Fig. 4) holds the cylindrical furnace between graphite support rods, which

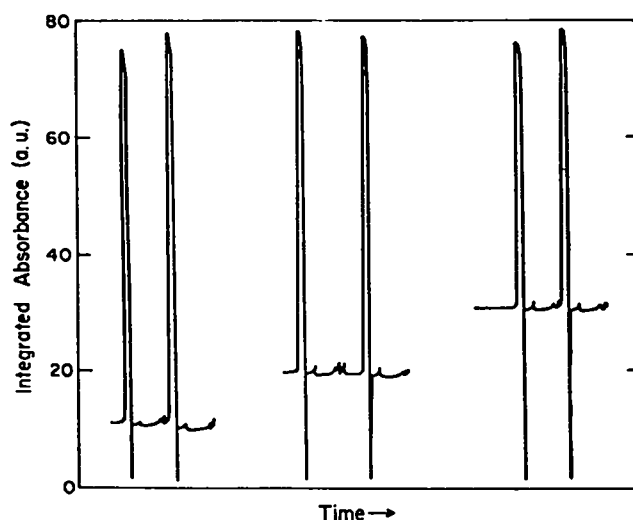

Fig. 3. Integrated absorbances of duplicate measurements of 0.2 μ g/ml chromium at three baseline settings.



Fig. 4. Graphite furnace holder.

extend from the water-cooled brass clamping blocks. A laminar flow of sheath gas (argon) around the furnace and support rods is provided by a 12.7-mm-thick graphite flow head, which contains seven rows of 1.59-mm holes about 2.38 mm apart. The left clamping block is spring loaded, maintaining good electrical contact between the furnace and support rods. Titanium guide rods are located on both sides of the spring. Because the unit is subjected to substantial quantities of acid fumes, a 0.0125-mm gold plate was applied to all brass parts.

The high currents (300 A) passed through the furnace during atomization require good electrical contact, particularly at the furnace. We found that when the graphite support rods and/or the furnace are changed, pronounced changes in sensitivity may occur within the first 10 to 20 firings. This is probably caused by changes in the nature of contact points at the furnace. If contact is not uniform over the surface of both support rods, high-resistance hot spots may result. The graphite at these spots burns away after a few firings, and the current density across the furnace cross section becomes more uniform. Thus, considerable care must be devoted to the positioning of the support rods and furnace.

APPLICATION TO PLUTONIUM ANALYSIS

To minimize the possibility of plutonium interference and to limit radioactive contamination, we use a procedure that separates plutonium from the other elements. The anion exchange method⁷⁻¹¹ depends on the fact that Pu(IV) in 7-8M HNO₃ is strongly held on highly basic anion exchange resin, whereas most other elements pass through.

We investigated only aluminum, copper, chromium, nickel, and iron here, but the method applies to many other elements. Detection limits were not established, mainly because the concentration of these elements normally found in plutonium are well above it. The low-reference materials now in use are (plutonium basis): Al - 10, Cu - 3, Cr - 2, Ni - 3, and Fe - 10, all in µg/g.

EXPERIMENTAL

Apparatus

- Beakers: Teflon, 30-ml
- Centrifuge cones: silica, 45-ml
- Evaporation apparatus: AUC-grade graphite block with 20 holes, Pyrex cover with exhaust hole, and 250-W infrared lamps
- Filter paper: Whatman No. 40 or equivalent
- Polyethylene vials: 5-ml
- Resin columns: plastic

Reagents and Materials

- Hydrochloric acid: 6.2M, distilled from silica apparatus and stored in polyethylene bottles
- Ion exchange resin: Bio Rad AG1-X8, 100-200 mesh, or equivalent
- For each sample, equilibrate 15 g of resin with 7.5M HNO₃.
- Transfer the resin to a plastic Buchner funnel containing a 90-mm-diam piece of Whatman No. 40 filter paper, apply a slight suction, and wash the resin with six 75-ml parts of 7.5M HNO₃.

Reference Materials

Reference solutions are prepared by diluting 1000 µg/ml stock solutions with 3M HNO₃. Table I shows the various concentrations in g/m³ (µg/ml).

TABLE I
CONCENTRATION OF IMPURITY ELEMENTS IN
REFERENCE SOLUTIONS

Solution No.	Concentration of Element (g/m ³)		
	Al, Fe	Cu, Ni	Cr
1	0.1	0.03	0.02
2	0.25	0.075	0.05
3	0.50	0.15	0.10
4	0.75	0.225	0.15
5	1.00	0.30	0.20
6	1.50	0.45	0.30
7	2.00	0.60	0.40
8	3.00	0.90	0.60

Procedure (Plutonium analysis with known impurity levels)

Place 100-mg portions of high-purity plutonium metal in each of five 30-ml Teflon beakers. Dissolve each portion in 0.5 ml of 6.2M HCl, and add 100, 200, 300, 400, and 500 μ l, respectively, of reference solution No. 8. Add 5-ml of 7.5M HNO₃ to each beaker and heat to 80°C. Place a silica wool plug in each resin column. Add resin to within about 20 mm of the top, and place a silica centrifuge tube beneath the column to collect the effluent solution. Add the plutonium solution carefully to the resin bed in increments of about 1 ml and wash the impurity elements through with 50 ml of 7.5M HNO₃. Collect 25 ml of the solution in each of two centrifuge tubes. Place the centrifuge tubes containing the effluent solution in the graphite block and evaporate at 105°C. When the volume has been reduced by about half, increase the temperature to 125°C until dryness is attained. Redissolve the residue by adding 2.5 ml of 7.5M HNO₃ to each of the hot tubes. Leave the tubes to cool about 1 h, then transfer each solution to a 10-ml silica volumetric flask. Rinse the tubes with two 2-ml parts of 1.5M HNO₃, transferring each from one tube to the other, and then into the volumetric flask. Dilute the solution to volume with 1.5M HNO₃. The absorption lines used for the analysis are 309.2 nm for aluminum, 324.7 nm for copper, 357.8 nm for chromium, 372.0 nm for iron, and 232.0 nm for nickel. Inject a 5- μ l sample of each into the furnace and subject to the drying, charring, and atomizing sequence described above.

Results are based on the measured integrated absorbance. Because changes in sensitivity occur, five reference solution aliquots are processed before and after the samples. If large differences (10% or more) are not evident, the values are averaged; otherwise the analysis must be repeated. Sample readings are usually repeated two or three times and the average value used.

DATA REDUCTION

Because calibration curves are nonlinear, a least-squares, second-degree fit is used. Higher order polynomials and exponentials have been tried with only slight improvement. The quadratic fit is reliable over only about a factor of 10 in concentration and must not be extrapolated further.

RELIABILITY

The RSD computed from 10 injections of the reference solutions at 3 different concentrations (Table II) show that precision is best at the intermediate concentration and tends to become poorer toward either extreme. This same trend is seen in flame AA.

TABLE II
PRECISION OF METHOD AT THREE CONCENTRATION LEVELS

Element	Concentration (μ g/ml)	RSD (%)
Al	0.10	6.6
	0.75	3.6
	2.00	3.8
Cr	0.02	2.6
	0.15	1.8
	0.40	2.2
Ca	0.03	5.6
	0.225	1.5
	0.60	1.8
Fe	0.10	7.3
	0.75	2.1
	2.00	2.4
Ni	0.04	6.8
	0.30	5.0
	0.80	2.2

TABLE III
RECOVERY OF KNOWN ADDITIONS OF IMPURITY
ELEMENTS FROM PLUTONIUM SOLUTIONS

Element	Element Added (μg)	Element Found (μg)	Bias (%)
Al	0.3	0.336	+ 12
	0.6	0.602	+ 0.3
	0.9	0.763	- 15.2
	1.2	1.13	- 5.4
	1.5	1.31	- 12.7
Cr	0.06	0.65	+ 8.3
	0.12	0.126	+ 5.0
	0.18	0.191	+ 6.1
	0.24	0.250	+ 4.2
	0.30	0.282	- 6.0
Cu	0.09	0.083	- 7.8
	0.18	0.193	+ 7.2
	0.27	0.277	+ 2.6
	0.36	0.367	+ 1.9
	0.45	0.465	+ 3.3
Fe	0.3	2.99	- 0.3
	0.6	5.62	- 6.3
	0.9	9.27	+ 3.0
	12	13.0	+ 8.2
	15	15.5	+ 3.1
Ni	0.09	0.095	+ 5.6
	0.18	0.204	+ 13.3
	0.27	0.273	+ 1.1
	0.36	0.370	+ 10.3
	0.45	0.490	+ 8.9

The bias of the method was determined at five concentration levels by comparing the measured content of each element in solutions with the known or prepared value. The results in Table III show that biases range from -15 to +13%, depending on the element and its concentration. The average biases for the entire method range from +4.6% for copper to -9.1% for aluminum. Considering the precision of measurement (Table III) and the error incurred in fitting the working curve, these biases

are quite reasonable. Overall, there is a small, unexplained, positive bias.

ACKNOWLEDGMENT

I wish to acknowledge H. M. Burnett for his assistance in initiating the design and construction of the special glovebox.

REFERENCES

1. B. F. Scribner and H. R. Mullins, "Carrier-Distillation Method for Spectrographic Analysis and Its Application to the Analysis of Uranium-Base Materials," J. Res. Nat. Bur. Stand., Sect. A, 37, 379-389 (1946).
2. C. F. Metz and G. R. Waterbury, "The Transuranium Actinide Elements," in *Treatise on Analytical Chemistry*, I. M. Kolthoff and P. J. Elving, Eds. (Interscience Publishers, New York, 1962), Vol. 9, pp. 189-426.
3. C. F. Metz, Paper 533, Proc. Intern. Conf. Peaceful Uses of Atomic Energy, Geneva, 1958, 17, 681 (1958).
4. R. Shank, J. E. Rein, G. A. Huff, and F. W. Dykes, "Facilities and Techniques for Analysis of Highly Radioactive Samples," Anal. Chem. 29, 1730, (1957).
5. J. P. Matsusek, "A Carbon Rod Atomizer for AAS," Am. Lab., 45, (1971).
6. K. M. Aldous, D. G. Mitchell, and F. J. Ryan, "Computer Controlled Atomic Absorption Spectrometer for Measurement of Transient Atom Populations," Anal. Chem., 45, 1990 (1973).
7. I. K. Kressin and G. R. Waterbury, "The Quantitative Separation of Plutonium from Various Ions by Anion Exchange," Anal. Chem., 34, 1598 (1962).
8. G. M. Allison and R. G. Hart, "The Separation of Plutonium by Anion Exchange in 10M Nitric Acid Solutions," Atomic Energy Canada, Ltd., Chalk River Project report PDB-86 (1953).
9. J. P. Faris and R. F. Buchanan, "Anion Exchange Characteristics of Elements in Nitric Acid and Nitrate Solutions and Application in Trace Element Analysis," Argonne National Laboratory report ANL-6811 (July 1964).
10. R. Ko, "Determination of Zirconium in Plutonium by Ion Exchange and Spectrography," U. S. At. Energy Comm. report HW-51831 (August 1957).
11. J. L. Ryan and E. J. Wheelwright, "Application of Anion Exchange to the Reprocessing of Plutonium," Second Intern. Conf. Peaceful Uses At. Energy, Geneva, (United Nations, New York, 1958) Vol. 17, p. 137.